

## Rehabilitation of Medium Expansive Soil Using Cement Treatment

Waddah S. Abdullah<sup>1)</sup> and Ahmed S. Alsharqi<sup>2)</sup>

<sup>1)</sup> Department of Civil Engineering, JUST, Irbid, Jordan. waddah@just.edu.jo

<sup>2)</sup> Jordan Engineers Association, Jordan

### ABSTRACT

Problematic soils such as swelling/shrinking soil are widespread in the Middle East and worldwide. This type of soil, upon wetting and drying, causes severe damage to structures built on such soil. Rehabilitation of swelling/shrinkage using cement treatment was studied in this work. Medium expansive soil ( $12 < PI < 24$ ) was selected for the present investigation. Soil specimens were mixed with various percentages of cement contents (1%, 2%, 3% and 4%) and molded to a range of prescribed pre-wetting dry densities and moisture contents. It was found that 2% cement content cured for 28 days was sufficient to reduce the free swell percentage for medium expansive soil from as high as 7.4% to merely 0.4%. The potential swell pressure, however, was reduced from a damagingly high value (333 kPa) for the untreated soil to a tolerable value (20 kPa) for the same enhancement conditions. Swell potential *versus* time relationship for the natural and stabilized soil could be very accurately represented by a rectangular hyperbolic function.

**KEYWORDS:** Expansive soils, Cement, Swell potential, Hyperbolic model.

### INTRODUCTION

Swelling/shrinking soils form a class of problematic soils, which causes severe damage to highways, structures and low-rise buildings. Swelling/shrinking soils, upon wetting and drying, cause severe damage to structures built on such soils. Road construction on a swelling/shrinking soil represents a serious challenge to geotechnical engineers, since the load exerted, comparatively, is very small. Manifestation of swell/shrink behavior can be observed as cracks in the surface of expansive soils (Plate 1) which may extend few meters below ground surface. Large depression in sidewalks constructed on expansive soils, due to the presence of bushes and trees, is also a clear manifestation of shrinkage in such problematic soils (Plate 2).

Rehabilitation of this type of “problematic soils” represents one of the alternatives to improve the properties of swelling/shrinking soils. Soil improvement is a process of alteration of the undesirable properties of soils in order, either to eliminate or to reduce the adverse behavior of such soils. For expansive soils, the amount of swell and shrink, on wetting and drying, causes uneven deformation or differential movements. TEX-124-E may be used to predict heave/shrink movement of foundations. However, the TEX-124-E was found to overpredict the heave/shrink movement values (Abdullah, 2002). Heave reduction factor should be used in combination with the TEX-124-E method to adjust the overprediction of heave/shrink movement (Abdullah, 2002). Few centimeters of differential movements may be sufficient to cause very severe damage even to well reinforced concrete structures (Plate 3). The swell/shrink phenomenon is influenced by physical parameters, such as pre-wetting dry density,

pre-wetting moisture content and degree of saturation as well as the environmental aspects of the region where the expansive soils are located (Abdullah, 2003; Mitchell and Soga, 2005). Matric suction, also, plays a paramount role in the swell behavior of soils (Fredlund et al., 1980; Fredlund and Morgenstern, 1977). The swell/shrink phenomenon is also influenced by chemical factors, such as type, valence and concentration of cations present on the "exchanger"; i.e. the clay mineral particles constituent of the soil and also influenced by the chemistry and pH of the pore fluid (van Olphan, 1977; Abdullah et al., 1999; Abdullah et al., 1996; Abdullah, 2003; Mitchell and Soga, 2005). The swell/shrink phenomenon is, also, influenced by types of clay minerals constituting the clay fraction present in soil (Abdullah, 2003; Mitchell and Soga, 2005). Each one of the above-mentioned factors has direct influence on the exchange complex and, hence, on the thickness of the diffuse double layer. The latter controls swelling/shrinking behavior of soils.

Soil improvement process may be conducted in a variety of techniques. Chemical stabilization was intended to affect and reduce the thickness of the diffuse double layer by introducing high concentration of specific type of cations (Abdullah et al., 1977; Abdullah, 2003; Abdullah et al., 1999). Method of introduction of such beneficial cations could be of classical nature; i.e. blending salts which on ionization provide the intended cations. Innovative methods, such as the electrokinetics methods, may be used to provide the required cations to soil (Abdullah and Al-Abadi, 2010). In the present work, soil was enhanced with cement at diverse percentages by dry mass of soil for the purpose of obtaining an optimum value of cement content which satisfies economical as well as technical requirements of transforming the problematic soil at hand into another soil having a tolerable and manageable amount of swell/shrink behavior.

### SCOPE OF WORK

This work studied the influence of soil cement

enhancement on swell potential characteristics of medium expansive soil. The study involved:

1. Blending cement with a medium expansive soil at various percentages by dry mass, and molding the soil-cement mixtures to produce specimens (20mm thick and 76 mm in diameter) ready for swell potential tests.
2. Cement treated soil specimens were cured for two periods of time (7-day period and 28-day period).
3. Considering the hyperbolic function to transform the implicitly defined swell potential *versus* time relationships obtained from the swell potential experiments into an explicitly defined mathematical function to be implemented, for instance, in a finite element analysis.

### MATERIALS AND METHODS

A medium expansive soil was selected for this study. The soil was taken from "JUST" campus site from a depth of about 2 m below ground surface. The soil sample was, first, air-dried; roots and foreign materials were removed and then pounded by a plastic hammer to break up soil lumps. The soil portion coarser than sieve No. 40 was discarded and the tests were carried out, only, on the portion finer than sieve No. 40.

#### Mineralogical Composition

X-ray diffraction method was utilized for identification of the different types of clay minerals present in the tested soil. In the clay mineral analysis, a random powder diffraction scan was made from the bulk sample after grounding to a fine powder in a ceramic mortar and pestle. To maximize random orientation, the powder was side-loaded into a circular sample holder. Air-dried (oriented), ethylene glycolated and heated (550°C for 1 hour) scans were also conducted.

The clay minerals present in "JUST" clay fraction were: kaolinite as major constituent, as well as montmorillonite and discrete illite as minor constituents. Kaolinite presence is evident as can be seen from the x-

ray diffractograms of the tested soil (Fig. 1). The strongest peaks of the kaolinite (d spacing in Å) are 7.12 and 3.58. These peaks disappeared and became amorphous to x-rays after heating to 550°C for 1 hr. Illite is unaffected by ethylene glycol solvation and

heating to 550°C. The peaks (d spacing in Å) 5.01 and 3.34 are indications of illite presence (Fig. 1). The peaks at 16.9 Å in the ethylene glycolated specimen and 5.01 Å in the air dried specimen are indicative of the presence of montmorillonite (Fig. 1).

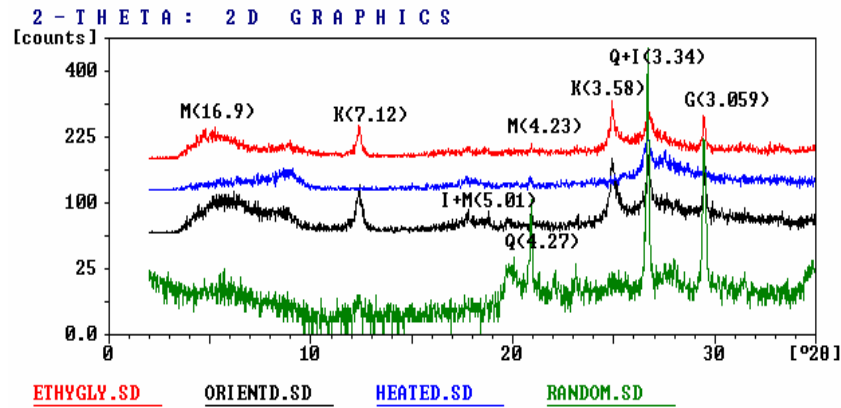

Figure 1: X-ray diffractograms for glycolated, random, heated and air dried JUST soil (K=kaolinite, I=illite, M=montmorillonite, Q=quartz, G=gypsum and ( ) d spacing in Å)

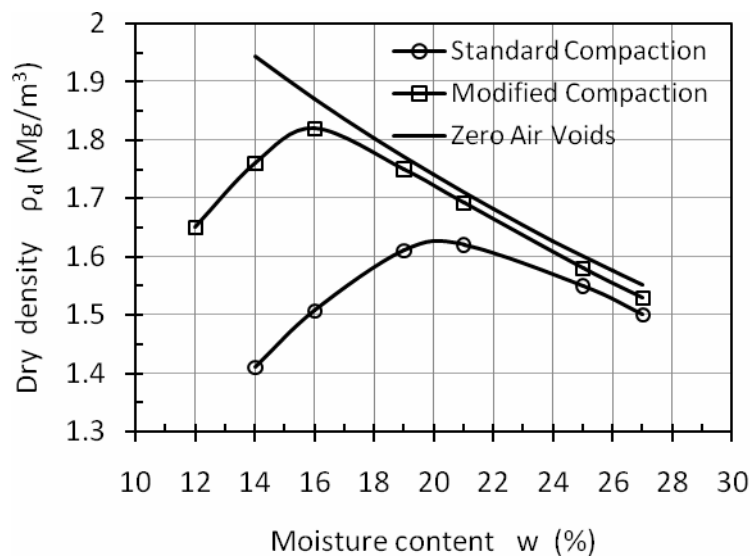

Figure 2: Dry density-moisture content relationship for “JUST” soil

**Basic Soil Properties Tests**

The following tests were conducted on “JUST” soil according to the ASTM. Liquid limit and plastic limit test according to ASTM 4318, specific gravity

according to ASTM D854, particle size distribution (mechanical method and hydrometer method) according to ASTM D421 and ASTM D422, respectively. The test results of “JUST” soil are given in Table 1. Standard

compaction and modified compaction tests were conducted according to ASTM D698 and ASTM D1557, respectively, and the test results are given in Table 1 and shown in Fig. 2 (Alsharqi, 1993).

Swell potential tests were carried out on "JUST" soil according to ASTM D4546; standard methods for one-dimensional swell or settlement potential of cohesive soils, Method A and Method C.

**Table 1. Basic soil properties of "JUST" soil (Al-Sharqi, 1993)**

Soil Property	Value
Depth of sample (m)	2.0
Specific gravity $G_s$	2.67
Activity	0.5
USC classification	CI-CH
Sand size (%)	13.5
Silt size (%)	35.5
Clay size (%)	51
Liquid limit LL	50
Plastic limit PL	26
Plasticity index PI	24
Maximum dry density $\rho_{dmax}$ ( $g/cm^3$ )	1.62
Optimum moisture content O.M.C. (%)	20.0
Maximum dry density $\rho_{dmax}$ ( $g/cm^3$ ) {Mod.}	1.82
Optimum moisture content O.M.C. (%) {Mod.}	16.0

#### Specimen Preparation for Swell Potential Tests

Each tested soil specimen was made at a predetermined dry density and moisture content. A circular mold (20 mm high and 76 mm in diameter) was used to produce soil specimens for swell potential tests. To make a soil specimen at a specific dry density and moisture content, a dry mass of the prepared soil to fit the volume of the mold at the required density was weighed and thoroughly mixed with the right amount of distilled water to achieve the prescribed moisture content. The moist soil was then placed in the mold and pressed by a hydraulic jack to exactly fit the mold. The mold was then disassembled to extract the soil specimen. The soil specimen was, then, gently placed over a porous stone in the testing ring. The ring was fixed with the clamp and the clamp was fixed to the testing cell by means of three screws. Another porous stone was placed on the top of the specimen. The assembled cell was placed in the oedometer swelling device and a small surcharge (6.9

kPa) was placed on the soil specimen, and the dial gauge was set to zero (Alsharqi, 1993).

#### Swell Potential Tests

To conduct free swell test according to ASTM D4546 Method A, distilled water was poured into the oedometer cell to start the test. The dial gauge readings were recorded at 0.25, 0.50, 1, 2, 4, 8, 15, 30, 60, 120 and 1440 minutes. By the end of a 24 hour period of time, all the tested specimens reached a state of no further swell activity with time. The percent free swell was calculated as the amount of swell (increase in specimen height) divided by the initial height of the soil specimen.

To conduct the potential swell pressure test (ASTM D4546 Method C), distilled water was poured into the oedometer cell to start the test. The soil specimen height was maintained constant (preventing swell of the specimen) by adding weight on the specimen just to keep it at its original height. The test was ended when

there was no observed swell activity. The swell pressure was calculated as the amount of added load to maintain

the specimen at its initial height divided by the area of the soil specimen.

**Table 2. Swell potential of untreated “JUST” soil (Al-Sharqi, 1993)**

Moisture content (%)	Dry density (g/cm <sup>3</sup> )	Free swell (%)	Swell pressure (kPa)
14.0	1.41	4.45	73.6
16.5	1.52	3.90	133.4
19.0	1.60	3.10	122.6
21.0	1.62	2.15	98.1
25.0	1.55	1.20	49.1
14.0	1.58	6.90	174.6
16.5	1.67	5.50	215.8
19.0	1.69	3.80	174.6
21.0	1.66	2.50	108.9
25.0	1.57	1.80	52.0
14.0	1.76	7.40	333.5
16.5	1.82	6.00	289.4
19.0	1.76	3.80	193.3
21.0	1.70	2.50	115.8
25.0	1.58	1.90	66.7

**Table 3. Classification of degree of expansiveness (William and Donaldson, 1980)**

PI	Degree of expansiveness
PI < 12	Low
12 < PI < 24	Medium
24 < PI < 32	High
PI > 32	Very high

**Preparing Soil Specimens with Cement Enhancements**

For a specific prescribed dry density, the dry mass of soil is determined and the mass of cement is then determined for a specific percent of cement. The dry mass of soil and the mass of cement were thoroughly mixed. Then the right amount of water (corresponding to a specific prescribed moisture content) was added and thoroughly mixed with the soil-cement mixture till homogeneity was achieved (Alsharqi, 1993). Soil

specimens were made as described above. Each produced soil specimen was securely wrapped with a plastic bag and thereafter with an aluminum foil and finally covered with a layer of wax to be kept for the required period of curing.

**Tests Results and Analysis**

Swell potential tests (free swell and potential swell pressure) were conducted on soil specimens having the following:

- i. Natural “JUST” soil with various pre-wetting dry densities and pre-wetting moisture contents and without cement enhancement.
- ii. Natural soil with cement enhancement with various pre-wetting dry densities and moisture contents and enhanced with various cement percentages (identical with the untreated soil) with 7-day curing period, and, 28-day curing period.

Swell potential test results for natural (untreated) “JUST” soil are given in Table 2 and shown in Fig. 3 and Fig. 4 for the swell percentage and potential swell pressure, respectively. According to (Williams and Donaldson, 1980) (Table 3), “JUST” soil belongs to a class of medium degree of expansiveness (PI = 24; the upper limit of medium degree of expansiveness).

The free swell value of “JUST” soil which is most representing the environmental characteristics of “JUST” area ( $w = 14\%$ ,  $\rho_d = 1.76 \text{ g/cm}^3$ ) was 7.4% and

the potential swell pressure was 333.5 kPa. These values happen to be the highest free swell and potential swell pressure values of all the tested soil specimens of “JUST” soil (Table 2). These values are unacceptably high, especially for road construction. Swell potential diagrams (Fig. 3 and Fig. 4) suggest an exponential response of swell potential (free swell and swell pressure) with respect to pre-wetting moisture content and dry density.

**Table 4. Parameters of the hyperbolic function**

Moisture content (%)	Dry density (g/cm <sup>3</sup> )	Added cement; and Curing period (%); (day)	Parameter <i>a</i>	Parameter <i>b</i>
16	1.52	0.0	1.359	0.2036
16	1.52	1; & 7	4.881	1.7185

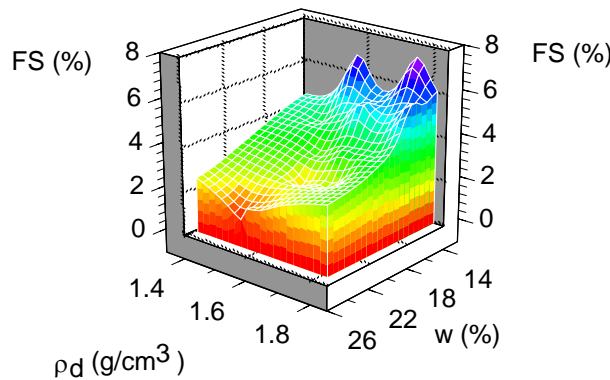

**Figure 3: Free swell for natural JUST soil**

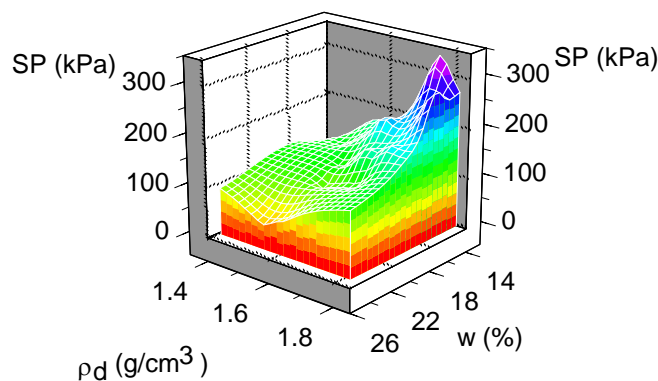

**Figure 4: Potential swell pressure of natural JUST soil**

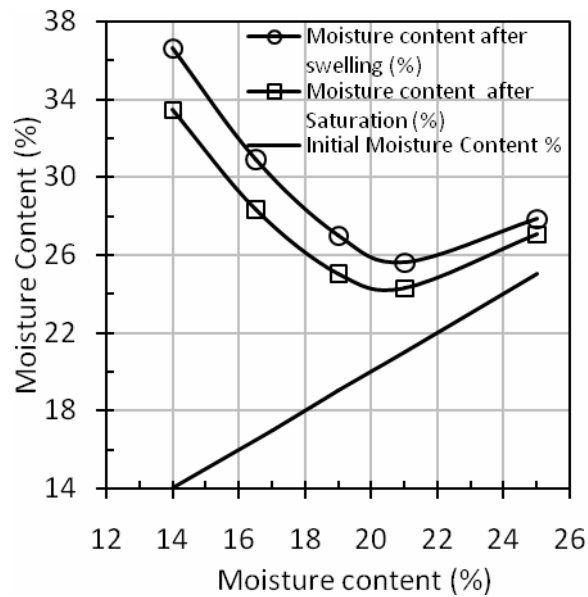

Figure 5: Moisture content at saturation and at the end of swelling for points corresponding to the standard compaction curve of JUST soil, (Al-Sharqi, 1993)

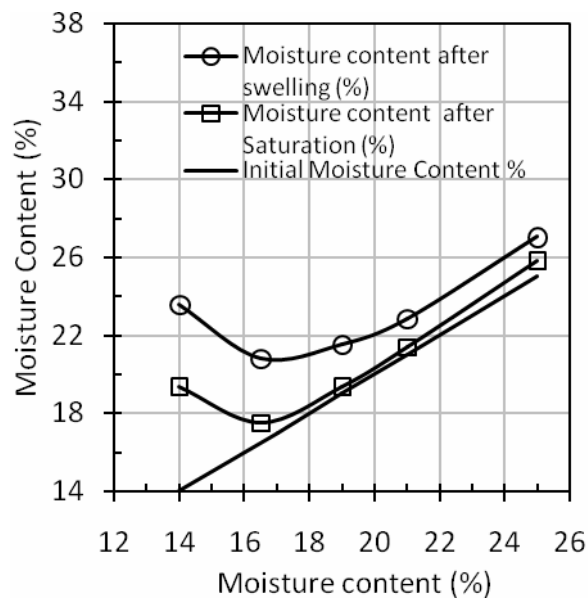

Figure 6: Moisture content at saturation and at the end of swelling for points corresponding to the modified compaction curve for JUST soil, (Al-Sharqi, 1993)

During the course of potential swell pressure test, the moisture content increased steadily until saturation was reached. During the course of the test, the volume of the soil specimen should be kept constant as the

concept of this particular test necessitates. In this specific case, the soil specimen continues taking water into soil pores until saturation is reached and no further water would be taken by the specimen. The amount of

potential swell pressure is directly related to the amount of water imbibed by the specimen (Fig. 5, and Fig. 6). The amount of imbibed water is the difference between the curve of the moisture content after saturation and the initial moisture content (Fig. 5 and Fig. 6). Conversely, during the course of percentage free swell test, the volume of the soil specimen is allowed to increase. As a matter of conception, the volume of soil solids does not increase and, hence, the increase occurs, only, in the volume of voids. Therefore, during the course of the test, water fills the original volume of voids as well as the additional volume of voids produced by the process

of swelling (Fig. 5 and Fig. 6). Hence, by the end of the test, the moisture content should be higher than the case of the potential swell pressure (Fig. 5 and Fig. 6). The higher the difference between the two curves the higher the potential swell pressure. The highest difference between the two curves is located in the dry side of optimum region (Fig. 5 and Fig. 6) as should be expected. Also, and since swell potential is expected to be higher when the dry density increases, the difference between the two curves widens up as we move from the standard compaction curve to the modified curve.

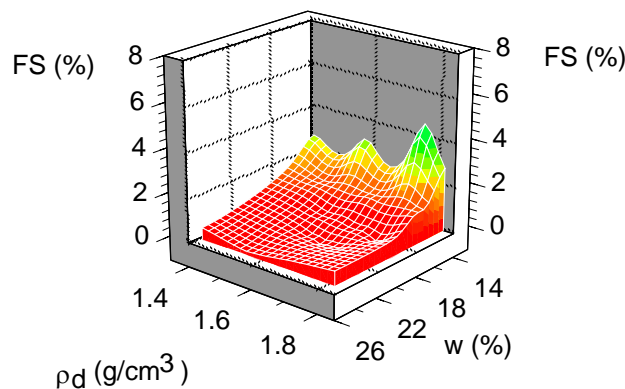

Figure 7: Free swell for treated JUST soil, 1% cement content and 7-day curing

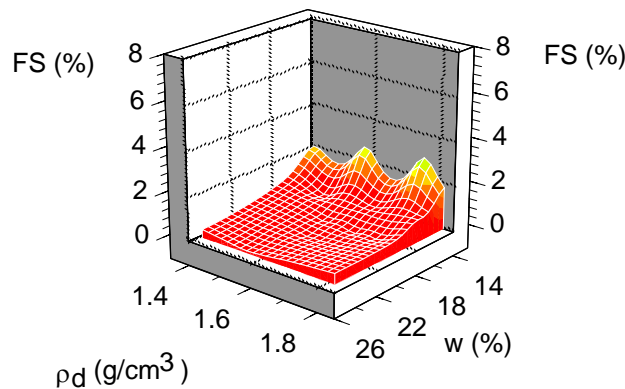

Figure 8: Free swell for treated JUST soil, 1% cement content and 28-day curing

**Cement Enhancement**

Portland cement was added to “JUST” soil in four cement percentages (1%, 2%, 3% and 4%) all with a 7-

day curing period and a 28-day curing period (Fig. 7 through Fig. 12). Since the 28-day period with 2% cement content was sufficient to reduce swell potential



drastically, 28-day curing period was only conducted for the first two percentages (Fig. 8 and Fig. 10). Large amount of reduction of free swell (Fig. 7 and Fig. 8) was observed even for small percentage of cement content as small as 1%, where highest swell value was reduced from 7.4% to about 4% and about 3% cured for 7-day period and 28-day period, respectively (Alsharqi, 1993). Using 2% of cement content was sufficient to

almost eradicate swell potential of “JUST” soil (Fig. 9 and Fig. 10). Using 3% and 4% cement content even for 7-day curing was enough to greatly reduce swell potential for “JUST” soil (Fig. 11 and Fig. 12). The highest swell percentage for the untreated “JUST” soil was reduced from 7.4% to merely 0.4% on using 2% cement content with 28-day curing period (Alsharqi, 1993).

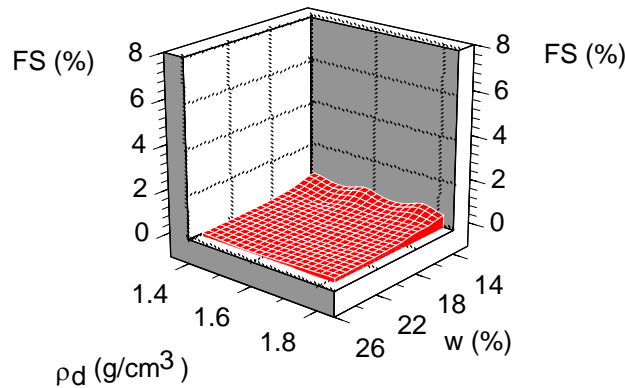

Figure 9: Free swell for treated JUST soil, 2% cement content and 7-day curing

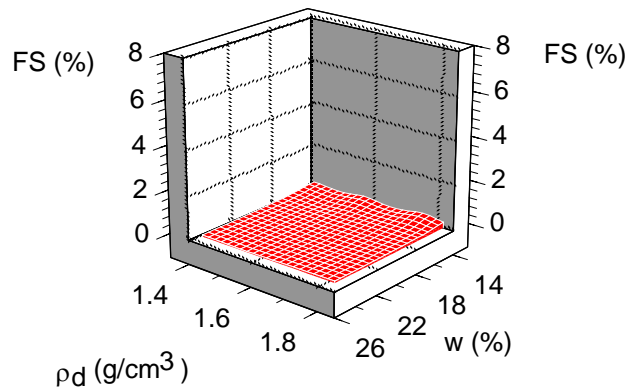

Figure 10: Free swell for treated JUST soil, 2% cement content and 28-day curing

Small percentages of cement contents (1% and 2%) were enough to drastically reduce the potential swell pressure (Fig. 13 through Fig. 15). The potential swell pressure was reduced from about 333 kPa for the untreated soil to 20 kPa on, only, using 2% of cement content (Fig. 15).

#### MODELING THE SWELL POTENTIAL –TIME RELATIONSHIP

Sophisticated analysis involving time-swell relationship such as the finite element analysis requires such relation to be in the form of an explicit

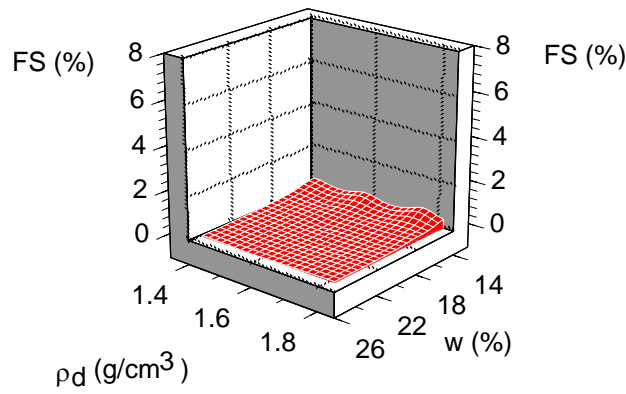

Figure 11: Free swell for treated JUST soil, 3% cement content and 7-day curing

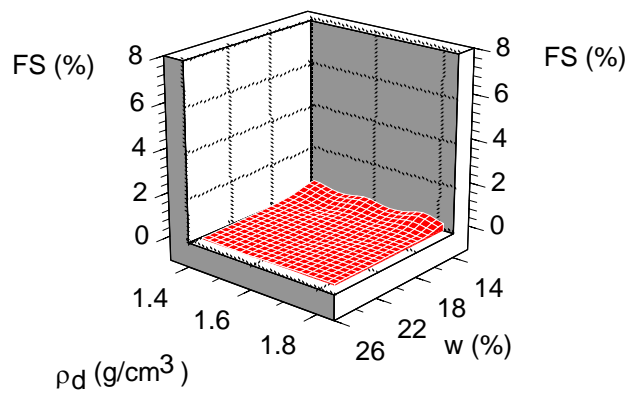

Figure 12: Free swell for treated JUST soil, 4% cement content and 7-day curing

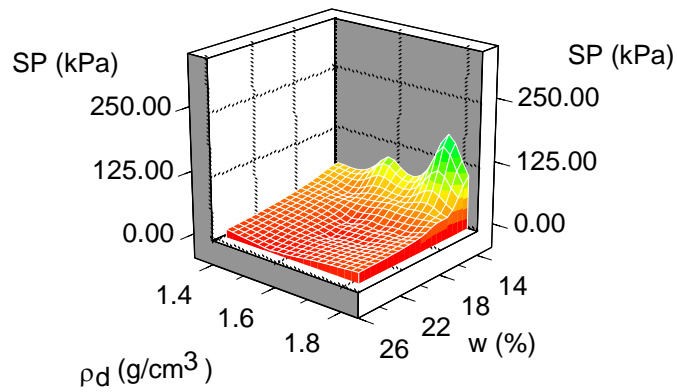

Figure 13: Swell pressure for treated JUST soil, 1% cement content and 7-day curing

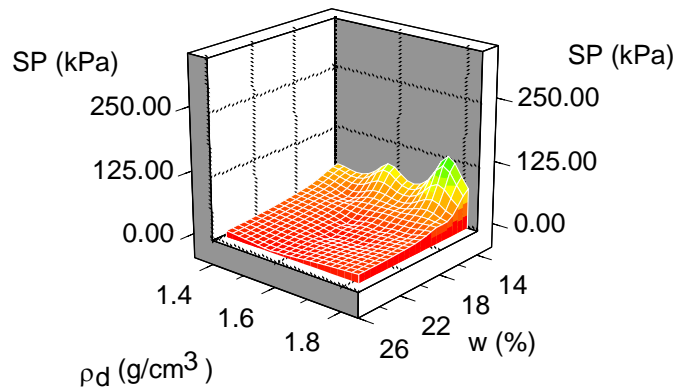

Figure 14: Swell pressure for treated JUST soil, 1% cement content and 28-day curing

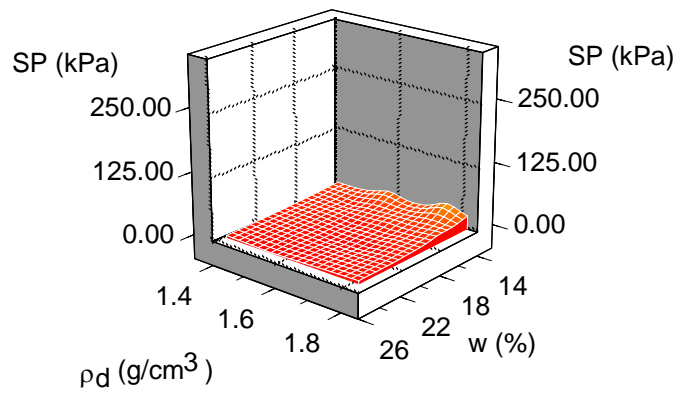

Figure 15: Swell pressure for treated JUST soil, 2% cement content and 7-day curing

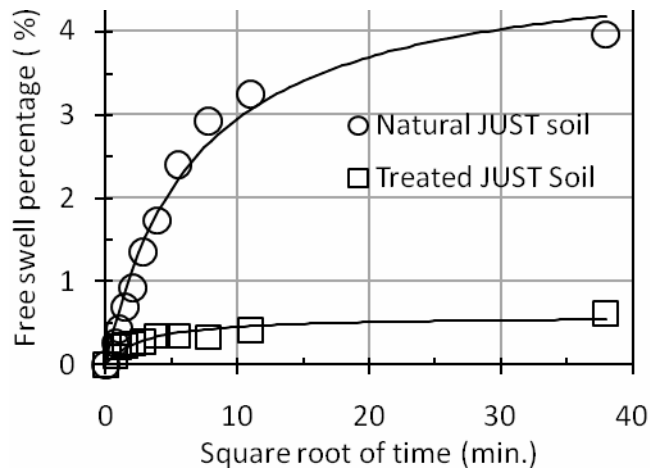

Figure 16: Free swell percentage versus square root of time relationship for JUST soil



**Plate 1: Seventeen cm wide crack in an expansive soil ripping off roots and stretching others**



**Plate 2: Large deformation caused by bushes in a sidewalk constructed on expansive soil**



**Plate 3: Severely damaged columns of a 2-storey building constructed on expansive soil**

mathematical function. The swell potential (free swell percentage or potential swelling pressure) versus square root of time always assumes a relationship similar to the one shown in Fig. 16 (Alsharqi, 1993). Rectangular hyperbolic function can successfully model such relationship. The hyperbolic function may be written as:

$$Sp(t) = \frac{\sqrt{t}}{a + b\sqrt{t}} \quad (1)$$

where:  $Sp$  is the swell potential whether percentage free swell or potential swell pressure,  $t$  is the time,  $a$  and  $b$  are the hyperbolic function parameters. Determination of the parameters ( $a$  and  $b$ ) may be achieved by linearization of the hyperbolic function. Linearization is done by introducing two new variables  $\eta$  and  $\xi$  (Eq. 2). The constants  $a$  and  $b$  are the slope and intercept of the best straight line fit of  $1/Sp$  versus  $1/\sqrt{t}$ , respectively;

$$\eta = \frac{1}{Sp} \quad \text{and} \quad \xi = \frac{1}{\sqrt{t}} \quad (2)$$

Substituting  $\eta$  and  $\xi$  in Equation (1) and rearranging terms yield:

$$\eta = a\xi + b \quad (3)$$

Plotting the data points in the  $\xi, \eta$  domain yields a straight line relation. Parameter  $a$  is the slope of the best fit line through the data points and parameter  $b$  is the intercept of this line.

The hyperbolic fit for natural “JUST” soil as well as soil enhanced with 1% cement and cured for 7-day period is shown in Fig. 16, and parameters  $a$  and  $b$  are given in Table 4. Undoubtedly, the hyperbolic fit produced an excellent functional relationship throughout the time span.

## SUMMARY AND CONCLUSIONS

The present work studied the influence of cement enhancement on “JUST” soil. JUST soil belongs to a class of medium degree expansiveness according to Williams and Donaldson (1980). Cement treatment was used at various percentages by dry mass of soil, with 7-day and 28-day curing periods. The following conclusions may be drawn:

1. Cement enhancement with as small as 1% or 2% by dry mass was sufficient to drastically reduce swelling potential. The highest swell percent of the untreated “JUST” soil was reduced from 7.4% to merely 0.4% on using 2% cement percentage and cured for 28-day period.
2. The potential swell pressure, however, was reduced from about 333 kPa for the untreated soil to 20 kPa on using 2% cement percentage cured for 28-day period.
3. The swell potential (free swell percentage or potential swell pressure) could be accurately modeled using rectangular hyperbolic function for the natural soil as well as the cement enhanced soil.

## REFERENCES

- Abdullah, W.S. and Al-Abadi, A.M. 2010. Cationic–electrokinetic improvement of an expansive soil, Elsevier, *Applied Clay Science*, 47: 343–350.
- Abdullah, W.S. 2002. Bidimensional swell effect on accuracy of footing heave prediction. *ASTM Geotechnical Testing Journal*, 25: 177-186.
- Abdullah, W.S. 2003. Physico-chemical picture and interpretation of swell potential of expansive soils and methods of stabilization. *Proceedings of the International Conference on Problematic Soils 1*, Nottingham Trent University, Nottingham, U.K., 145-152, 29-30 July.
- Abdullah, W.S., Alshibli, K.A. and Al-Zou’bi, M.S. 1999. Influence of pore water chemistry on the swelling behavior of compacted clays. *Applied Clay Science*, 15: 447-462.

- Abdullah, W.S., Al-Zou'bi, M.S. and Alshibli, K.A. 1996. On the physicochemical aspects of compacted clay compressibility. *Canadian Geotechnical J.*, 34: 551-559.
- Alsharqi, A.S. 1993. Swelling characteristics of cement-stabilized Jordanian clay, Thesis submitted to Civil Engineering Department in Partial Fulfillment of the Master Degree of Science in Civil Engineering, Jordan University of Science and Technology, Irbid, Jordan.
- Fredlund, D.G. and Morgenstern, N.R. 1977. Stress state variables for unsaturated soils, *Soil Mechanics and Foundation Division*, ASCE, 103: 447-466.
- Fredlund, D.G., Hasan, J. U. and Filson, H.L. 1980. The prediction of total heave, *Proceedings of the Fourth International Conference on Expansive Soils*, American Society of Civil Engineers, ASCE, 1: 16-18, June 16-18, Denver, Colorado, USA.
- Mitchell, J.K. and Soga, K. 2005. Fundamentals of soil behavior. 3<sup>rd</sup> Edition, John Wiley and Sons, Inc.
- Van Olphen, H. 1977. An introduction to clay colloid chemistry – for clay technologists, geologists and soil-scientists, 2<sup>nd</sup> Edition, Wiley-Interscience Publication, John Wiley and Sons, New York.
- Williams, A.B. and Donaldson, G.W. 1980. Building on expansive soils in South Africa: 1973-1980, *4th International Conference on Expansive Soils*, Vol. 2, Denver, Colorado, June, 16-18.