

## Numerical Modeling of Flow Pattern in Spillway Approach Channel

*Abbas Parsaie<sup>1)</sup>, Amir Moradinejad<sup>2)</sup> and Amir Hamzeh Haghiabi<sup>3)</sup>*

<sup>1)</sup> Ph.D. Candidate of Hydro-structures, Department of Water Engineering, Lorestan University, Khorram Abad, Iran. E-Mail: Abbas\_Parsaie@yahoo.com

<sup>2)</sup> Ph.D. Candidate of Hydro-structures, Department of Water Engineering, Lorestan University, Khorram Abad, Iran. E-Mail: amir\_24619@yahoo.com

<sup>3)</sup> Associate Professor of Water Engineering, Lorestan University, Khorram Abad, Iran. E-Mail: Haghiabi@yahoo.com

### ABSTRACT

Analysis of behavior and hydraulic characteristics of flow over the dam spillway is a complicated task that takes lots of money and time in water engineering project planning. To model these hydraulic characteristics, several methods, such as physical and numerical methods, can be used. Nowadays, by utilizing new methods in computational fluid dynamics (CFD) and by the development of fast computers, numerical methods become accessible for use in the analysis of such sophisticated flows. CFD softwares have the capability to analyze two-and three- dimensional flow fields. In this paper, the flow pattern at the guide wall of Kamal-Saleh dam was modeled by Flow 3D. The results show that the current geometry of the left wall causes instability in the flow pattern and makes the secondary and vortex flows at the beginning approach channel. This shape of guide wall reduces the performance of weir to remove the pick flood discharge.

**KEYWORDS:** Approach channel, Kamal-Saleh dam, Guide wall, Flow pattern, Numerical modeling, Flow 3D software.

### INTRODUCTION

Spillways are among the main structures used in dam projects. Design of spillways in all types of dam, specifically earthen dams, is important, because the inability of the spillway to remove Probable Maximum Flood (PMF) discharge may cause overflow of water, which ultimately leads to destruction of the dam (Das and Das Saikia, 2009; E.D.O.A., 2013; Novak et al., 2007). So, studying the hydraulic characteristics of these structures is important. Hydraulic properties of spillway include flow pattern at the entrance of the guide walls and along the chute. Moreover, estimating the values of

velocity and pressure of flow along the chute is very important (Chanson, 2004; Chatila and Tabbara, 2004). The purpose of studying the flow pattern is to examine the effect of wall geometry on the creation of transverse waves, flow instability and rotating and reciprocating flows through the inlet of the spillway and its chute (Parsaie and Haghiabi, 2015; Parsaie et al., 2015; Wang and Jiang, 2010). The purpose of studying the values of velocity and pressure is to calculate the potential of the structure to occurrence of phenomena such as cavitation (Fattor and Bacchiega, 2009; Ma et al., 2010). Sometimes, it can be seen that the spillway design parameters of pressure and velocity are very suitable, but the geometry considered is not suitable for conducting walls, causing an unstable flow pattern over the spillway, rotating flows at the beginning of the

---

Received on 28/1/2015.

Accepted for Publication on 31/7/2015.

spillway and reduction of flood discharge capacity (Fattor and Bacchiega, 2009). Studying spillways is usually conducted by making physical models (Su et al., 2009; Suprpto, 2013; Wang and Chen, 2009; Wang and Jiang, 2010). But, recently, with advances in computational fluid dynamics (CFD), studying hydraulic characteristics of such structures has been increasingly carried out by using CFD techniques (Chatila and Tabbara, 2004; Zhenwei et al., 2012). Using CFD techniques as powerful techniques for modeling hydraulic structures can reduce both the time and cost of experiments (Tabbara et al., 2005). In CFD field, the Navier-Stokes equation is solved by powerful numerical methods, such as finite element method and finite volume method (Kim and Park, 2005; Zhenwei et al., 2012). In order to obtain a closed form of Navier-Stokes equation turbulence models,  $k - \varepsilon$  and Re-Normalization Group (RNG) models have been presented. Computational fluid dynamics software packages, such as Fluent and Flow 3D, ... etc., have been provided. Recently, these two software packages have been widely used in hydraulic engineering, because the performance and accuracy of these software packages are very suitable (Gessler; Kim, 2007; Kim et al., 2012; Milési and Causse, 2014; Montagna et al., 2011). In this paper, in order to assess the flow pattern at Kamal-Saleh guide wall, the numerical method has been used. All the stages of numerical modeling were conducted using the Flow 3D software.

## MATERIALS AND METHODS

Firstly, a three-dimensional model was constructed according to a two-dimensional map that was prepared for designing the spillway. Then, a small model with a scale of 1:80 was prepared and entered into the Flow 3D software. All stages of model construction were conducted in AutoCAD 3D. Flow 3D software solved numerically the Navier-Stokes equation by finite volume method. Below is a brief reference to the equations used in the software. Figure (1) shows the 3D sketch of Kamal-Saleh spillway and Figure (2) shows

the uploading file of Kamal-Saleh spillway in Flow 3D software.

## Review of the Governing Equations in Software Flow3D

Continuity equation at three-dimensional Cartesian coordinates is given as shown in Eq. (1).

$$v_f \frac{\partial \rho}{\partial t} + \frac{\partial}{\partial x}(uA_x) + \frac{\partial}{\partial y}(vA_y) + \frac{\partial}{\partial z}(wA_z) = \frac{PSOR}{\rho} \quad (1)$$

where  $u$ ,  $v$  and  $w$  are the velocity components in the  $x$ ,  $y$  and  $z$  directions.  $A_x$ ,  $A_y$  and  $A_z$  are cross-sectional areas of the flow,  $\rho$  is the fluid density,  $PSOR$  is the source term and  $v_f$  is the volume fraction of the fluid. Three-dimensional momentum equations are given as shown in Eq. (2).

$$\begin{aligned} \frac{\partial u}{\partial t} + \frac{1}{v_f} \left( uA_x \frac{\partial u}{\partial x} + vA_y \frac{\partial u}{\partial y} + wA_z \frac{\partial u}{\partial z} \right) &= -\frac{1}{\rho} \frac{\partial P}{\partial x} + G_x + f_x \\ \frac{\partial v}{\partial t} + \frac{1}{v_f} \left( uA_x \frac{\partial v}{\partial x} + vA_y \frac{\partial v}{\partial y} + wA_z \frac{\partial v}{\partial z} \right) &= -\frac{1}{\rho} \frac{\partial P}{\partial y} + G_y + f_y \\ \frac{\partial w}{\partial t} + \frac{1}{v_f} \left( uA_x \frac{\partial w}{\partial x} + vA_y \frac{\partial w}{\partial y} + wA_z \frac{\partial w}{\partial z} \right) &= -\frac{1}{\rho} \frac{\partial P}{\partial z} + G_z + f_z \end{aligned} \quad (2)$$

where,  $P$  is the fluid pressure,  $G_x$ ,  $G_y$  and  $G_z$  are the accelerations created by body fluids,  $f_x$ ,  $f_y$  and  $f_z$  are the viscosity accelerations in the three dimensions and  $v_f$  is related to the volume of the fluid as shown in Eq. (3). For modeling of free surface profile, VOF technique based on the volume fractions of the computational cells has been used. Since the volume fraction  $F$  represents the amount of fluid in each cell, it takes a value between 0 and 1.

$$\frac{\partial F}{\partial t} + \frac{1}{v_f} \left[ \frac{\partial}{\partial x}(FA_x u) + \frac{\partial}{\partial y}(FA_y v) + \frac{\partial}{\partial z}(FA_z w) \right] = 0 \quad (3)$$

## Turbulence Models

Flow 3D offers several types of turbulence model: Prantl mixing length model,  $k-\varepsilon$  equation, RNG model and large eddy simulation model. Turbulence models that have been recently proposed are based on Reynolds-

averaged Navier–Stokes equations. This approach involves statistical methods in order to extract an averaged equation related to the turbulence quantities.

### Steps of Solving a Problem in Flow 3D Software

1- Preparing the 3D model of spillway by AutoCAD software. 2-Uploading the file of 3D model in Flow 3D software, defining the problem in the software and checking the final mesh. 3- Choosing the basic equations that should be solved. 4-Defining the characteristics of the fluid. 5- Defining the boundary conditions, where it is notable that this software has a wide range of boundary conditions. 6- Initializing the flow field.7- Adjusting the output. 8- Adjusting the control parameters and selecting the calculation method and solution formula. 9- Starting the calculation. Figure (1) shows the 3D model of Kamal-Saleh spillway. In this figure, the geometry of the left and right guide walls is shown.

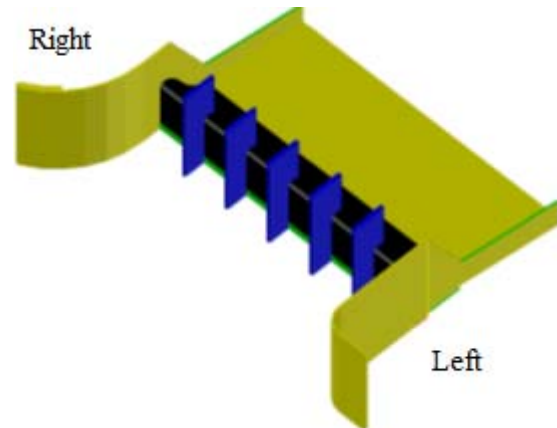


Figure (1): Sketch of approach channel and spillway of Kamal-Saleh dam

Figure (2) shows the uploading of the 3D spillway dam in Flow 3D software. Moreover, in this figure, the boundary condition considered in the software is shown. At the entrance and end of the spillway, the flow rate or fluid elevation and outflow were considered. The bottom of the spillway was considered as wall and left and right as symmetry.

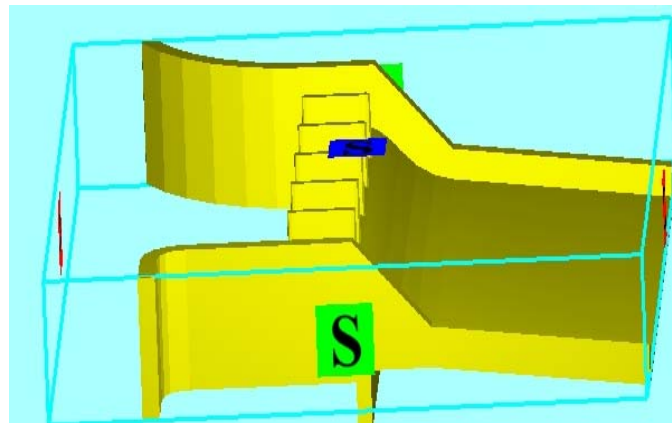


Figure (2): 3D model of Kamal Saleh dam in Flow 3D software

## RESULTS AND DISCUSSION

The behavior of water in a spillway is strongly affected by the flow pattern at the entrance of the spillway. The flow pattern formation at the entrance is affected by the guide wall, where the choice of an

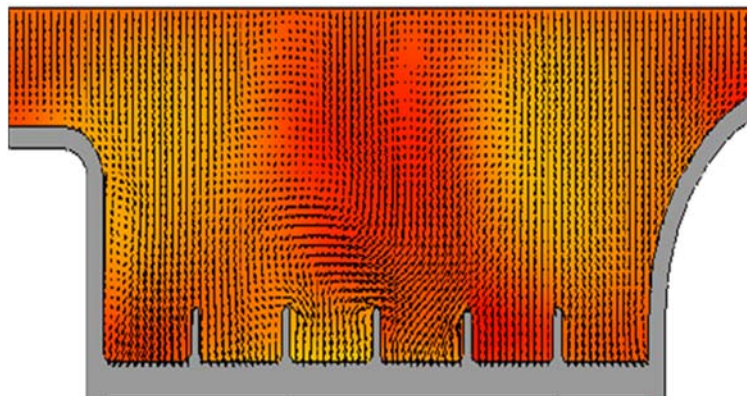
optimized form for the guide wall has a great effect on rising the ability of the spillway for easy passing of the PMF. So, any non-uniformity in flow in the approach channel can cause a reduction in spillway capacity, as well as a reduction in the discharge coefficient of the spillway and even the probability of cavitation.

Optimizing the flow guiding walls (in terms of length, angle and radius) can cause loss of turbulence and flow disturbances on the spillway. For this purpose, initially, the geometry proposed for the model of discharge of Kamal-Saleh dam spillway [80, 100 and 120 L/s] was surveyed. These discharges of flow were considered with regard to flood return periods of 5, 100 and 1000 years. Geometric properties of the conducting guidance walls are given in Table (1).

**Table 1. Characteristics and dimensions of the guidance walls tested**

Case	Direct length (m)	Radius of curvature (m)	Curvature (degree)
1	0.200	0.325	90
2	0.375	0.175	120
3	0.100	0.400	110

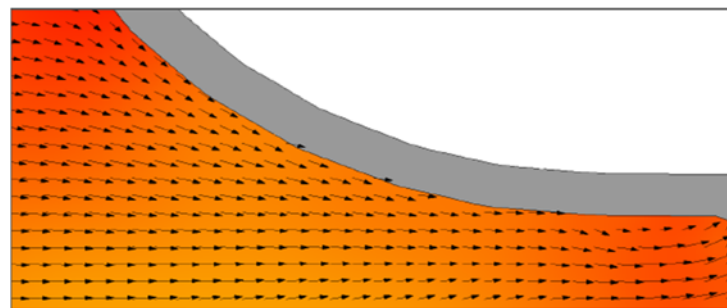
Results of the CFD simulation for passing the flow rate 80 (L/s) are shown in Figure (3). Figure (3) shows the secondary flow and vortex at the left guide wall.



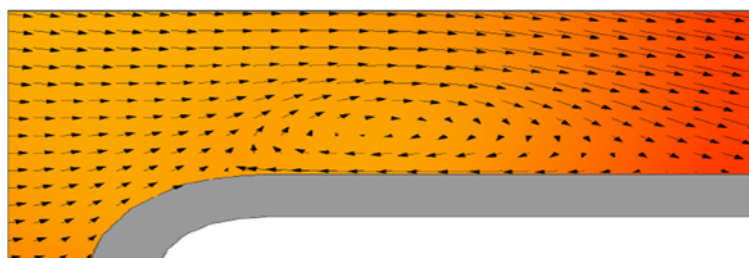
**Figure (3): Flow pattern in the approach channel for the flow rate 80 (L/s)**

For giving more information about flow pattern at the left and right guide walls, Figure (4) shows the flow

pattern at the right side guide wall and Figure (5) shows the flow pattern at the left side guide wall.

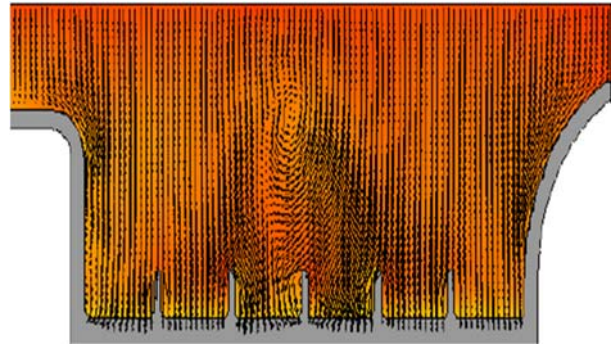


**Figure (4): Flow pattern through the right side guide wall**



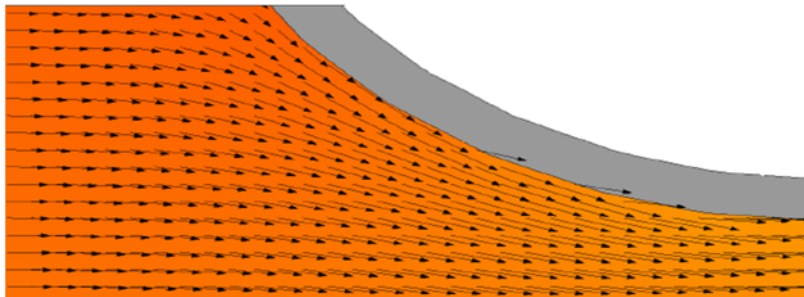
**Figure (5): Flow pattern through the left side guide wall**

With regard to Figures (4) and (5) and observing the streamlines, at a discharge equal to 80 (L/s), the right wall has a suitable performance, but the left wall has no suitable performance. The left wall of the geometric design creates a secondary circular flow and vortex motion in the beginning of the entrance of the spillway, which creates cross-waves at the beginning of the spillway. By increasing the flow rate ( $Q=100$  L/s), at the inlet spillway, secondary flows and vortex motion were removed, but the streamline has severe distortion. Results of the guide wall performance at  $Q=100$  (L/s) are shown in Figure (6).

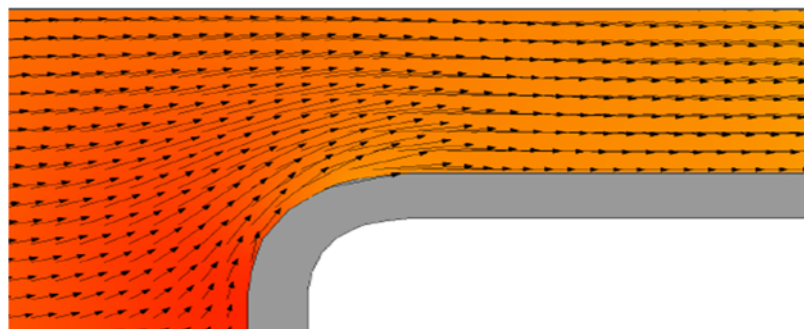


**Figure (6): Proposed model at a flow rate of 100 (L/s)**

More information about the performance of each guide wall is shown in Figures (7 and 8). These figures show that secondary and vortex flows were removed, but the streamline was fully diversified, specifically near the left side guide wall.



**Figure (7): Flow pattern down the right wall**

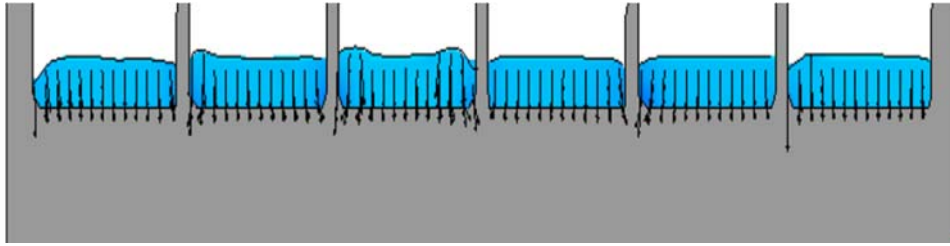


**Figure (8): Flow pattern through the left side wall**

As previously mentioned, secondary and vortex flows and diversion in streamline cause non-uniformity

and create cross-waves through the spillway. Figure (9) shows the cross-waves at the crest of the spillway.

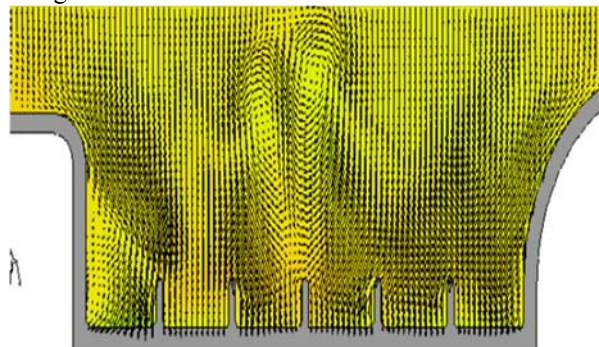




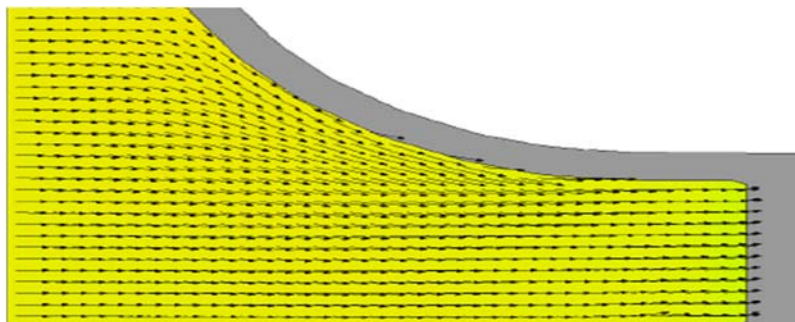
**Figure (9): Two-dimensional flow pattern on the spillway crest**

The performance of guide walls at  $Q=120$  (L/s) was also assessed. The result of simulation is shown in Figure (10). Figures (11 and 12) show a clearer view of the streamlines near to the right side guide wall and left

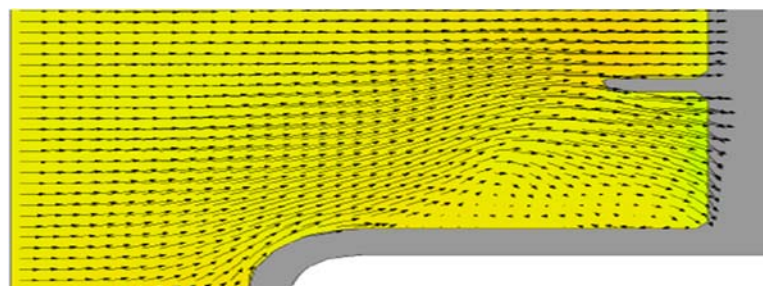
side guide wall, respectively. As seen in Figure (12), the left side wall still causes vortex flow and creates diversion in the streamline.



**Figure (10): Flow pattern at a flow rate of 120 (L/s)**



**Figure (11): Flow pattern near the right wall**



**Figure (12): Flow pattern near the left wall**

The result of the effect of the left side guide wall shape on cross-wave creation is shown in Figure (13).

As seen from Figure (13), the left side guide wall causes cross-waves at the spillway crest.

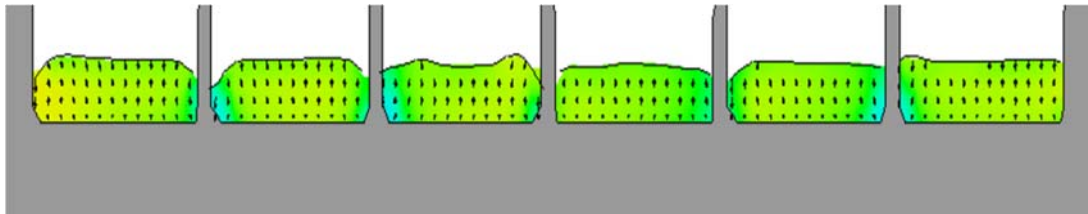


Figure (13): Two-dimensional flow pattern on the left side guide wall at the spillway crest

As clearly seen from Figures (9 and 13), by moving from the left side to the right side of the spillway, cross-waves and non-uniformity in flow are removed. By reviewing Figures (9 and 13), it is found that the right side guide wall causes removing cross-waves and non-uniformity. At this point, a geometry similar to that of the right side guide wall was considered instead of the geometry of the left side guide wall. The result of simulation for  $Q=120$  (L/s) is shown in Figure (14). As seen from this figure, the proposed geometry for the left side wall has a suitable performance, smoothly passing the flow through the approach channel and spillway.

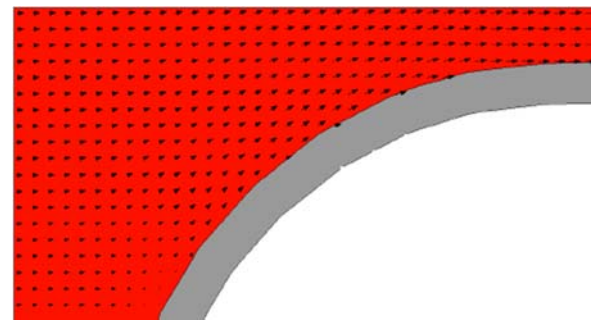


Figure (15): Guiding the flow pattern near the wall

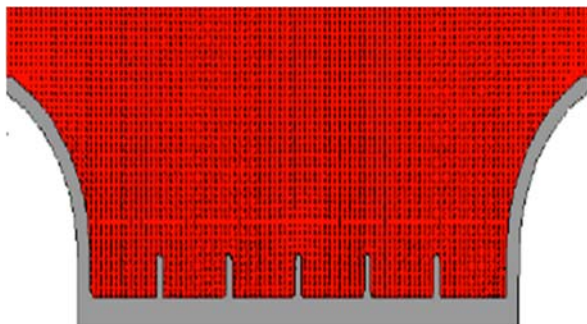


Figure (14): Proposed model for a flow rate of 120 (L/s)

More information about the proposed shape for the left side guide wall is shown in Figure (15). As seen from this figure, this shape has a suitable performance for removing cross-waves and vortex flows.

Figure (16) shows the cross-section of flow at the crest of the spillway. As seen from this figure, the proposed shape for the left side guide wall is suitable for removing cross-waves and secondary flows.

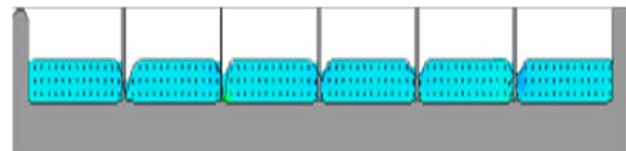


Figure (16): Two-dimensional flow pattern on the wall of the spillway crest

## CONCLUSION

Analysis of behavior and hydraulic properties of flow over a spillway dam is a complicated task that takes lots of money and time. There are several techniques in correspondence to the purpose of this research. Physical modeling, usage of experts' experiences and usage of mathematical models in simulating flows in one-

dimensional, two-dimensional and three dimensional techniques are among the appropriate techniques to study this phenomenon. The results of modeling show that the CFD technique is a suitable tool for simulating

the flow pattern on the guide wall. Using this tool helps edit unsuitable geometries of hydraulic structures in light of that flow patterns through them are of great importance.

## REFERENCES

- Chanson, H. (2004). "19 designs of weirs and spillways". In: H. Chanson (Ed.), *Hydraulics of Open Channel Flow (Second Edition)*, Oxford, Butterworth-Heinemann, 391-430.
- Chatila, J., and Tabbara, M. (2004). "Computational modeling of flow over an ogee spillway". *Computers and Structures*, 82, 1805-1812.
- Das, M. M., and Das Saikia, M. (2009). "Irrigation and water power engineering". PHI Learning.
- E. D. O. A. U. S. A. C. O. (2013). "Hydraulic design of spillways". Biblio-Bazaar.
- Fattor, C., and Bacchiega, J. (2009). "Design conditions for morning-glory spillways: application to Potrerillos dam spillway". *Advances in Water Resources and Hydraulic Engineering*, Springer, Berlin, Heidelberg, 2123-2128.
- Gessler, D. "CFD modeling of spillway performance". *Impacts of Global Climate Change*, 1-10.
- Kim, D. G. (2007). "Numerical analysis of free flow past a sluice gate". *ASCE J. Civ. Eng.*, 11, 127-132.
- Kim, D., and Park, J. (2005). "Analysis of flow structure over ogee-spillway in consideration of scale and roughness effects by using CFD model". *ASCE J. Civ. Eng.*, 9, 161-169.
- Kim, S., Yu, K., Yoon, B., and Lim, Y. (2012). "A numerical study on hydraulic characteristics in the ice harbor-type fishway". *ASCE J. Civ. Eng.*, 16, 265-272.
- Ma, X. D., Dai, G. Q., Yang, Q., Li, G. J., and Zhao, L.L. (2010). "Analysis of influence factors of cavity length in the spillway tunnel downstream of middle gate chamber outlet with sudden lateral enlargement and vertical drop aerator". *Journal of Hydrodynamics*, Ser. B, 22, 680-686.
- Milési, G., and Causse, S. (2014). "3D numerical modeling of a side-channel spillway". In: P. Gourbesville, J. Cunge and G. Caignaert (Eds.). *Advances in Hydroinformatics*, Springer, Singapore, 487-498.
- Montagna, F., Bellotti, G., and Di Risio, M. (2011). "3D numerical modeling of landslide-generated tsunamis around a conical island". *Nat. Hazards*, 58, 591-608.
- Novak, P., Moffat, A. I. B., Nalluri, C., and Narayanan, R. (2007). "Hydraulic structures". Fourth Edition, Taylor and Francis.
- Parsaie, A., and Haghiabi, A. (2015). "The effect of predicting discharge coefficient by neural network on increasing the numerical modeling accuracy of flow over side weir". *Water Resources Management*, 29, 973-985.
- Parsaie, A., Yonesi, H., and Najafian, S. (2015). "Predictive modeling of discharge in compound open channel by support vector machine technique". *Model. Earth Syst. Environ.*, 1, 1-6.
- Su, P. L., Liao, H. S., Qiu, Y., and Li, C.J. (2009). "Experimental study on a new type of aerator in spillway with low Froude number and mild slope flow". *Journal of Hydrodynamics*, Ser. B, 21, 415-422.
- Suprpto, M. (2013). "Increase of spillway capacity using Labyrinth weir". *Procedia Engineering*, 54, 440-446.
- Tabbara, M., Chatila, J., and Awwad, R. (2005). "Computational simulation of flow over stepped spillways". *Computers and Structures*, 83, 2215-2224.
- Wang, J., and Chen, H. (2009). "Experimental study of elimination of vortices along guide wall of bank spillway". *Advances in Water Resources and Hydraulic Engineering*, Springer, Berlin, Heidelberg, 2059-2063.



Wang, Y., and Jiang, C. (2010). "Investigation of the surface vortex in a spillway tunnel intake". *Tsinghua Science and Technology*, 15, 561-565.

Zhenwei, M. U., Zhiyan, Z., and Tao, Z. (2012). "Numerical simulation of 3-D flow field of spillway based on VOF method". *Procedia Engineering*, 28, 808-812.