

## Cyclic Behavior of Pipe Dampers Reinforced with High-performance Fiber-Reinforced Cementitious Composite (HPFRCC) Materials

Ali Lahooti<sup>1)</sup>, Arash Sayari<sup>2\*</sup> and Salar Manie<sup>3)</sup>

<sup>1), 2), 3)</sup> Department of Civil Engineering, Sanandaj Branch, Islamic Azad University, Sanandaj, Iran.  
E-Mails: L\_civil\_ali@yahoo.com; Sayari\_51@yahoo.com; salarmanie@yahoo.com

\* Corresponding Author. E-Mail: Sayari\_51@yahoo.com

### ABSTRACT

High-Performance Fiber-Reinforced Cementitious Composite (HPFRCC) materials are among the new materials used in recent years and have drawn the attention of structure engineers. High tension resistance in comparison to regular concrete and high ability for energy depreciation are among the advantages of these materials. Passive yielding dampers have also attracted the attention of structure engineers. Steel dampers are among novel dampers which, in spite of simple structure, possess high performance in energy depreciation, plus other advantages, such as being replaceable after the quake, simple structure, possibility of installation in different positions in pipe form in reigning systems, ... etc. The coming survey investigates the effect of strengthening and combining pipe dampers by using HPFRCC materials. The findings show that strengthening pipe dampers by HPFRCC materials could dramatically depreciate the amount of energy entering the system and boost the efficiency of pipe dampers.

**KEYWORDS:** Pipe dampers, High-Performance Fiber-Reinforced Cementitious Composites (HPFRCCs), Cyclic behaviour, Cement-based fiber composites.

### INTRODUCTION

The need for sustainable development and the ever increasing use of concrete in construction industries pushed scholars to innovate concretes with higher abilities. Studies in this field recently led to completion of regular concretes and enhancement of appearance of different types of concrete known today as high-performance concrete (HPC). Cement-based fiber concretes (High-Performance Fiber-Reinforced Cementitious Composites (HPFRCCs)) are among the modern high-performance concretes lately put under the focus of construction engineers. HPFRCCs are a group of fiber-reinforced cement-based composites which, in

contrary to regular concrete, show strain hardening under tensile force, where the tensile strength may reach ten times the strength of regular concrete. Strain hardening appears after the first fracturing and leads to form multiple cracks or in other words micro-cracks (Wang and Li, 2005; JSCE, 2008; Cho et al., 2012). Principally, HPFRCCs are materials with high ductility, well-distributed micro-cracks' model under large deformation situation and strain hardening under tensile force, as shown in Figure 1 (Fischer and Li, 2002; Parra-Montesinos and Chompreda, 2007; Yuan et al., 2013; Canbolat et al., 2005; Dang et al., 2016; Wu et al., 2017; Olsen and Billington, 2011; Jen et al., 2016) (Fig.1). Unique properties of HPFRCC materials, reinforced HPFRCC members and their advantages compared to regular concrete under biaxial and multi-axial loading have put such materials, among other modern materials,

---

Received on 24/10/2019.

Accepted for Publication on 29/2/2020.

such as thermoplastics that can be used in construction industry, in the focus of studies of many scholars (Pokhrel and Bandelt, 2019; Kang et al., 2017; Wu et al., 2018; Foltz et al., 2017; Bencardino et al., 2017; Conforti et al., 2016; Choi et al., 2017; Shbeeb and Al-Rousan, 2018).

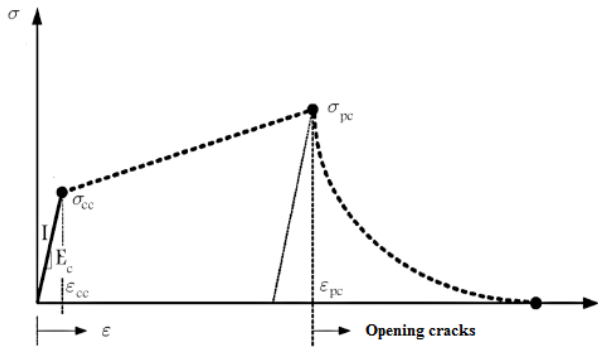

**Figure (1): Relation between strain and stress in (HPFRCCs) under tensile force**

The efficiency of a building could be increased by adding dampers to it. Dampers are the waste factor of the shudder energy to the building. This advantage recovers the tremor performance of the structure under quake loads (Ngekke et al., 2019).

Advantages of damper use are as follows:

- Decreasing of change and relative change in the place of building stories.

- Outstanding decrease in acceleration of stories.
- Marked decrease of structure and non-structure damage.
- Decrease of operation costs due to use of sections with less capacity.

A pipe damper is an energy waste system based on plastic behaviour, which shows an acceptable behaviour in bending. When pipe dampers are simultaneously placed under bending and shear deformation, they show a gradual stiffening behaviour. Dual-pipe dampers are classified under yielding dampers. Dual-pipe dampers were innovated by Mahjoub and Maleki (Mahjoub and Maleki, 2016). Pipe dampers could be categorized as a new generation of yielding dampers with high efficiency. Advantages of these dampers are; simple structure in design, high performance and effectiveness.

Studies on the performance of dual-pipe reinforced dampers with zinc metal were carried out by Mahjoub and Maleki (Mahjoub and Maleki, 2016) in order to reinforce (strengthen) tubes; they were filled with lead and zinc melt under static load. The results from hysteresis graphs demonstrated that this reinforcing method could lead to friction between internal and external tube and increase the stiffness and depreciation of energy. Figs. 2-4 show the deformation of test samples during cyclic loading while showing a sample of the hysteresis graph for reinforced pipe dampers (Figs. 2-4).

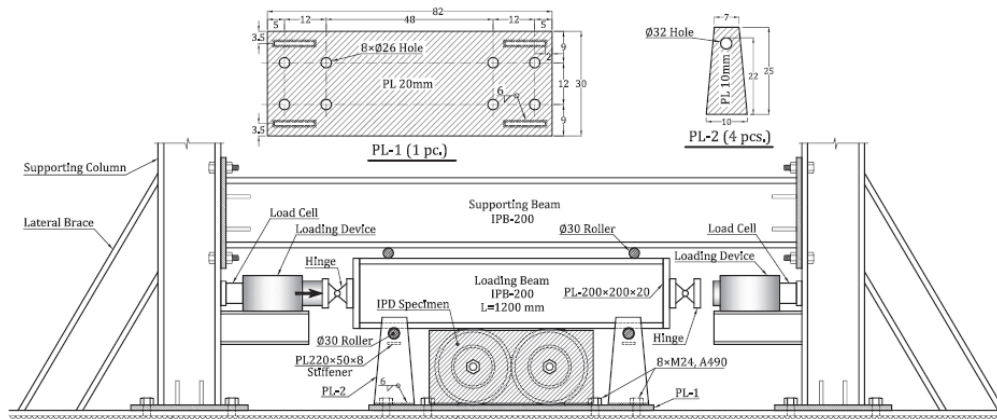

**Figure (2): Test set-up for pipe dampers**



Figure (3): Deformation of tested specimens under cyclic loading

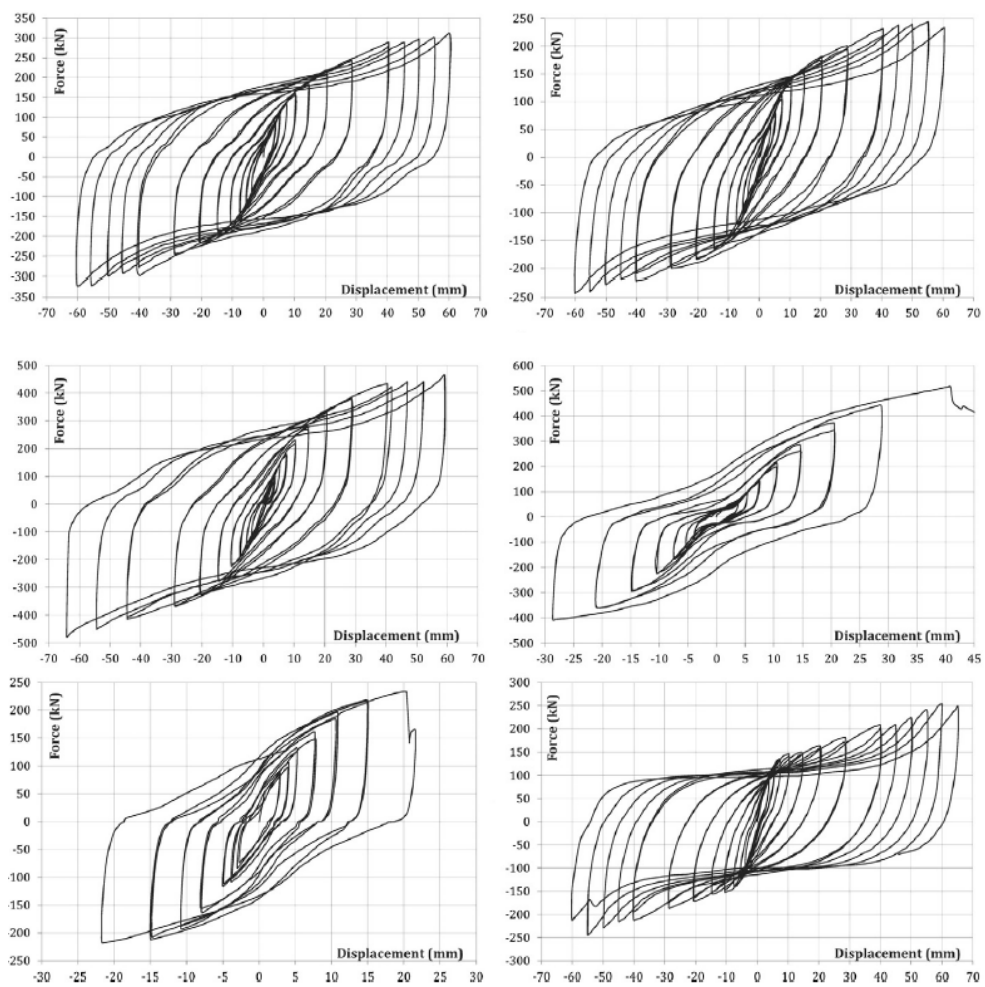

Figure (4): Hysteresis graphs for reinforced pipe dampers

As seen in Mahjoub and Maleki (2016), the reinforcement of a dual-pipe damper can lead to improved damping performance in cyclic loads. In this paper, pipe damper strengthening by HPFRCC is proposed to enhance pipe damper performance under cyclic loading. For this purpose, after validation of a pipe damper and HPFRCC, performance of pipe damper strengthening by HPFRCC was studied. Performance of pipe damper strengthening by HPFRCC was examined

with energy dissipation factor and simulation was conducted by finite element method ABAQUS software.

**Validity Measurement**  
**Pipe Damper Validity**

In order to validate the pipe damper, a lab specimen which underwent cyclic loading in ABAQUS software environment was simulated. Fig. 5 shows the details of the lab sample (Maleki and Bagheri, 2010).

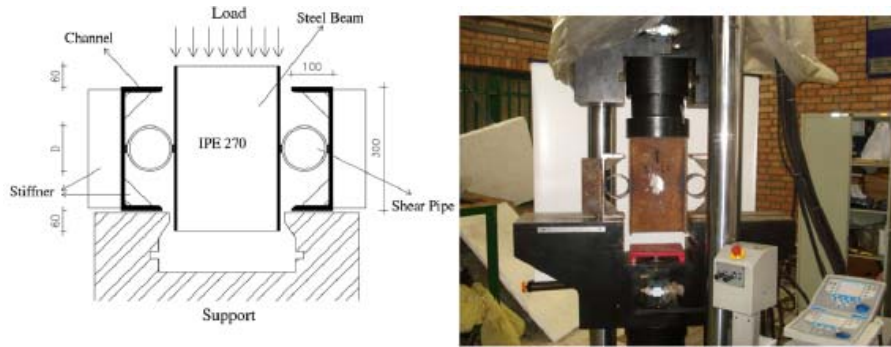

Figure (5): Details of lab-tested specimen

Mechanical specifications of lab steel sample appear in Table 1.

Table 1. Mechanical specifications of lab steel sample

Diameter (mm)	Thickness (mm)	Modulus of elasticity (GPa)	Yield stress (MPa)	Ultimate stress (MPa)	Breaking strain (%)
140	4	200	355	410	25

In order to simulate pipe damper in ABACUS software, shell element has been used. Fig. 6 shows lab specimen and finite element specimen simulated in ABAQUS, as well as the sample mesh used for pipe damper. Fig 7 shows the compliance of simulation specimen graph with lab specimen match, which confirms the correctness of simulations.

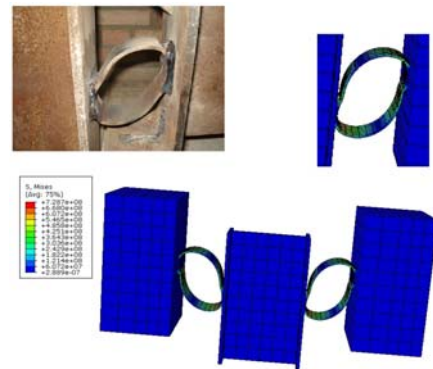

Figure (6): Compliance of lab specimen with finite element specimen

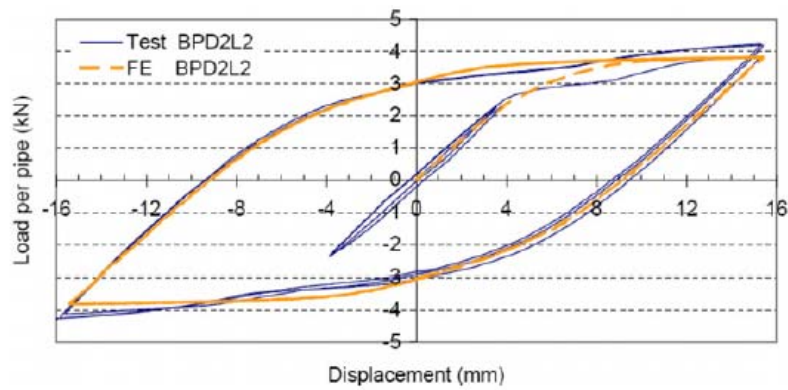

Figure (7): Simulation graph and lab specimen match

**Validity of High-Performance Fiber-Reinforced Cementitious Composites (HPFRCCs)**

In order to simulate fiber concrete behaviour and its particular specifications, Concrete Damage Plasticity (CDP) method has been utilized. Concrete damage plasticity method is the only model which could be utilized in both static and dynamic analyses for compression and disintegration of samples. In this model, it is assumed that the tensile fracture covers the two principal disintegration mechanisms and is designed for modelling of tender fractures of concrete under cyclic loading (alternate compression and tension), such that it is possible to recycle the hardness during reciprocating loads. In plastic damage model, due to lack of disintegration criteria, it is not possible to eliminate elements during fracture analysis or crack development, but this model could forecast the place and

direction of fractures. ABACUS is a finite element analysis software which has the ability of modelling concrete damage plasticity. In this model, there are two separate mechanisms considered for simulation of concrete, which makes it possible to simulate concrete compression and tensile behaviour. Below you will find out that fiber concrete behaviour under tensile and compression forces has been manifested. Following graphs known as coat graphs made by connection of maximum load tension during loading, in which:  $E$ =modulus of Young,  $\epsilon_{t0}$  = first cracking strain,  $\sigma_{t0}$  = first cracking stress,  $\epsilon_{tp}$  = strain at peak stress in tension,  $\sigma_{tp}$  = strength in tension,  $\epsilon_{tu}$  = tensile strain capacity,  $\epsilon_{cp}$  = strain at peak stress in compression,  $\sigma_{cp}$  = strength in compression,  $\epsilon_{cu}$  = ultimate strain in compression,  $\sigma_{cr}$  = stress corresponding to  $\epsilon_{cu}$  (Na and Kwak, 2011), see Fig. (8).

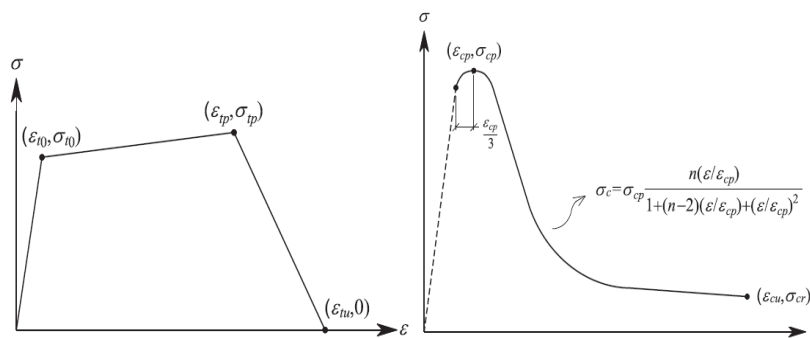

Figure (8): Tensile (a) and Compressive (b) fiber behaviour of concrete

When fracture appears in reinforced concrete, it could still tolerate some tension in the direction perpendicular to the fracture. This phenomenon is called ‘remaining rigidity and tension phenomenon’. To introduce concrete tensile behaviour to the software, use was made of obeisance along with simple linear model in order to model the concrete tensile behaviour.

The major behaviour for fiber cementitious composites was compared with that of regular concrete

by showing their different behaviours concerning tension. In order to validate fiber concrete, a dumbbell-like specimen (Fig. 9) has been simulated in the lab through ABACUS software, matching the real sample (Fig. 10) (Quang et al., 2016). In order to test non-linear behaviour of concrete, a 20-node element of solid form has been utilized. Fig. 11 shows the 20-node element utilized to simulate concrete.

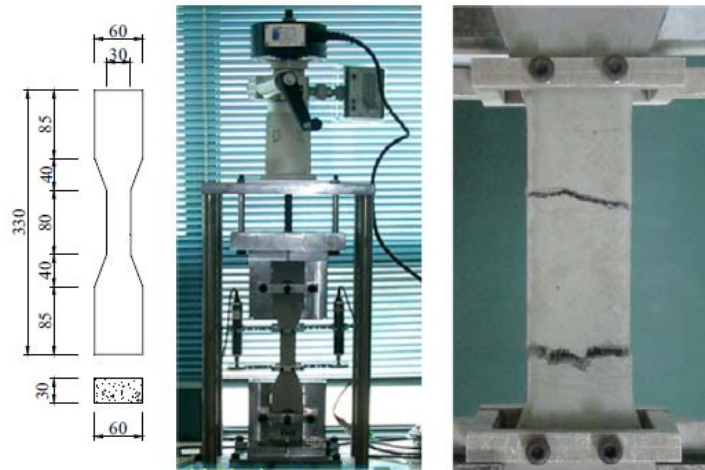

Figure (9): Details of dumbbell specimen studied in lab environment

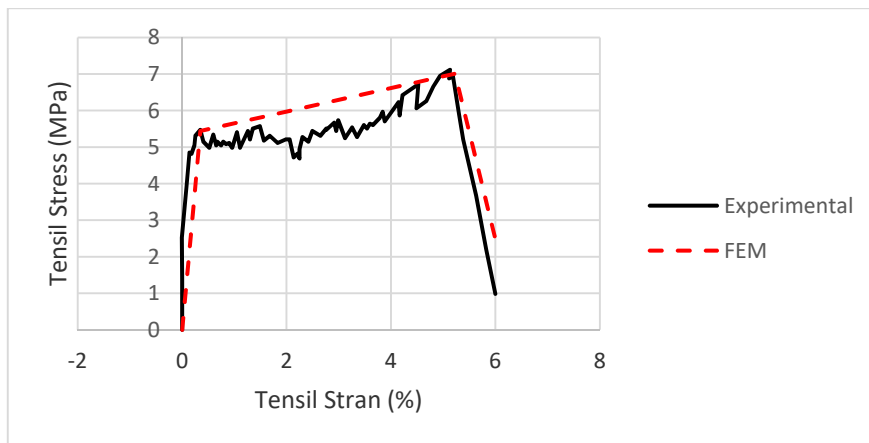

Figure (10): Compliance of lab sample and simulated specimen in software environment



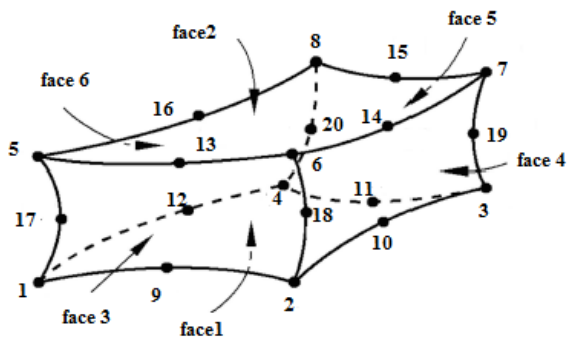

Figure (11): 20-node element utilized to simulate concrete

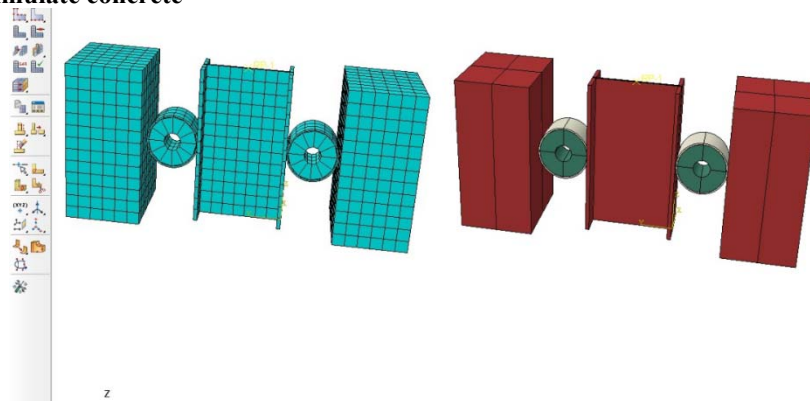

Figure (12): Schematic model of reinforced pipe element with HPFRCC and meshing of the set

Figure 13 shows the index of damage incurred to the pipes. As observed from the picture, the extent of damage inflicted to reinforced pipes with HPFRCC is higher than that in single-pipe dampers.

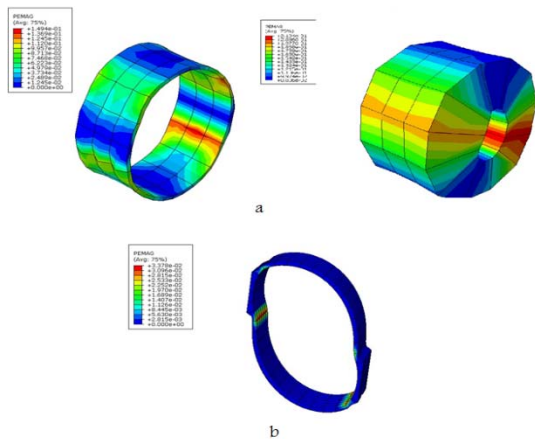

Figure (13): Index of damage a) reinforced specimen with HPFRCC b) simple specimen pipe

### STUDYING SPECIMENS

In order to study the effect of pipe dampers strengthened with HPFRCC, a verified specimen (Maleki and Bagheri, 2010) reinforced with 30mm thick HPFRCC and cyclic behaviour was investigated. The cyclic loading of the investigated specimen is in accordance with the laboratory sample. Figure 12 is a schematic model reinforced by pipe damper element with HPFRCC and shows the mesh grid of the complex.

Von Mises tension has been shown for two specimens in Fig. 14. As can be seen in the picture, in reinforced sample with HPFRCC, tension has spread in all sections of the pipe damper. This shows a consistent distribution of tension on the damper. In other words, it could be said that reinforcement of pipe dampers through composite base leads to consistent distribution throughout the whole section of the pipe damper (Fig 14).

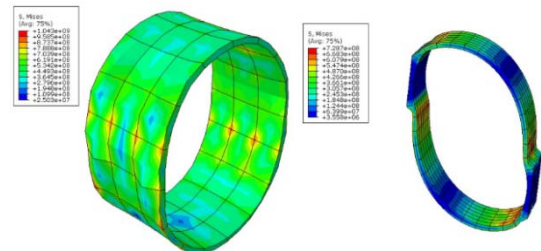

Figure (14): Von Mises tension in pipe damper (right) and pipe damper with base composite matter (left)

Hysteresis graph in reciprocation (coming and going) could leave an effective influence on the behaviour of the structure and its members. Illustrating the graph of load against change of place in coming and going is called hysteresis graph. Hysteresis behaviour for both samples has been investigated.

In order to analyze the models, the following principles are considered:

- A) The area under the curve of hysteresis expresses the inconsistency of the structure against load coming and going. The more symmetry in the graph, the more consistent the structure behavior against quake.
- B) Symmetry in hysteresis graph shows inconsistency in structure behavior in motion back and forth. The more symmetry in the graph, the more consistent the behavior against quake.
- C) If the graph slope decreases in cycles, the structure loses rigidity.

- D) As the height of the graph decreases repeatedly, the structure's resistance lowers.
- E) As the height of the graph increases repeatedly, the structure shows rigidity.
- F) If the graph is not consistent in a path's cycle, the structure is slippery.
- G) Number of graph cycles expresses the functioning of the structure against quake.

Figures (15-17) show hysteresis graphs for steel sample damper and steel damper reinforced with HPFRCC. Addition of HPFRCC to steel damper makes it more rigid. Considering the internal area of hysteresis graph, it could be said that pipe damper reinforcement with HPFRCC leads to increase of depreciated energy. The area under steel graph rings is 1139.68 (kN.mm<sup>2</sup>) and adding HPFRCC increases the figure to 24738 (kN.mm<sup>2</sup>), which is 21.7 times the depreciation of energy in the system.

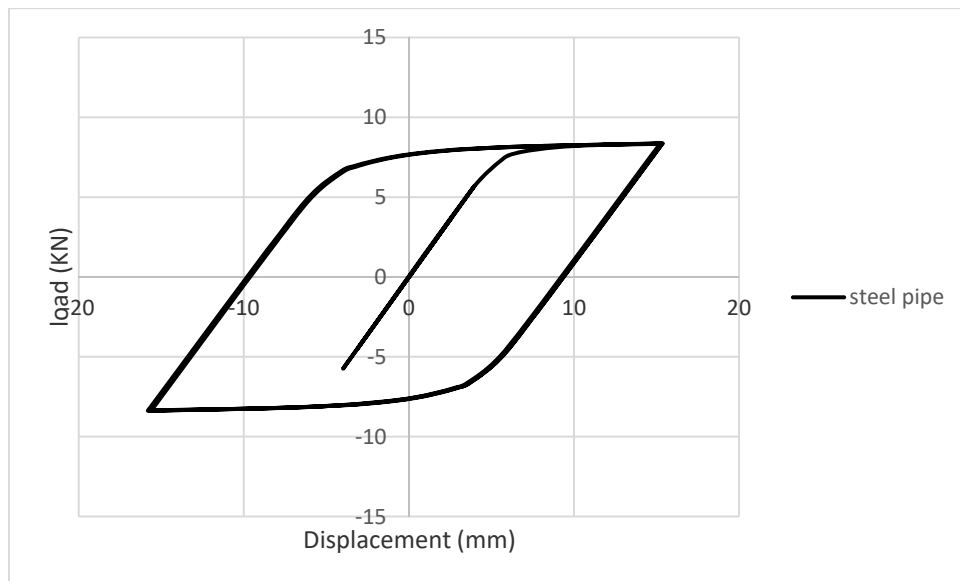

Figure (15): Hysteresis graph for pipe damper



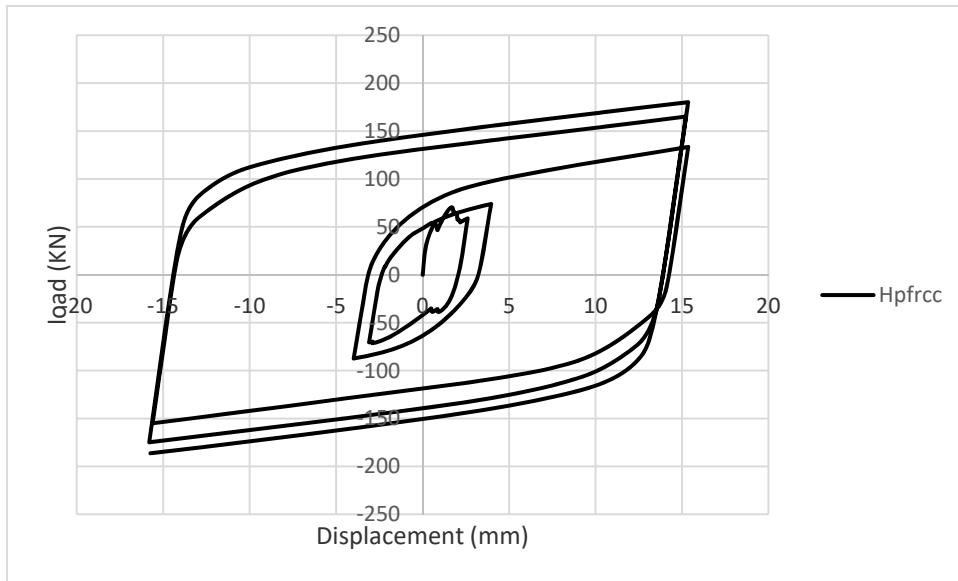

Figure (16): Hysteresis graph for pipe damper reinforced with HPFRCC

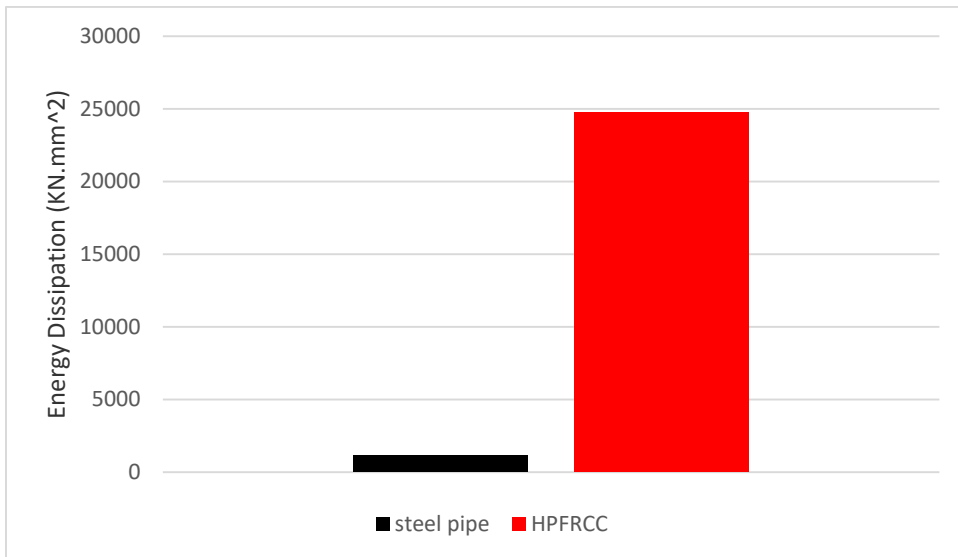

Figure (17): Comparison of depreciated energy for pipe damper and for pipe damper reinforced with HPFRCC

**CONCLUSIONS**

In this paper, we propose pipe damper strengthening by HPFRCC to enhance pipe damper performance under cyclic loading. For this purpose, after validation of a pipe damper and HPFRCC, the performance of pipe damper strengthening by 30mm thick HPFRCC was

studied. The performance of pipe damper strengthening by HPFRCC was examined with energy dissipation factor and simulation was conducted by ABAQUS finite element method software. The finite element analysis showed that:

1. Von Mises tension in sample reinforced with HPFRCC has spread in all sections of the pipe

damper. In other words, it could be said that reinforcement of pipe dampers through HPFRCC leads to consistent distribution throughout the whole section of the pipe damper.

2. According to the damage index in steel and HPFRCC, it was found that micro-crack creation in the HPFRCC has an important role in increasing the amount of depreciated energy.
3. Addition of HPFRCC to steel damper increases the stiffness of the damper in the elastic zone.
4. Reinforced dampers have the benefits of steel dampers with higher amount of resistance.
5. Considering the internal area of hysteresis graph, it could be said that reinforcement of pipe damper with HPFRCC leads to increase depreciated energy.
6. The plastic behavior of the steel damper area, the HPFRCC plastic behavior and the friction between the HPFRCC and steel significantly increased the amount of energy dissipation.
7. The area under steel graph rings is 1139.68 (kN.mm<sup>2</sup>) and adding HPFRCC increases the figure to 24738 (kN.mm<sup>2</sup>) which is 21.7 times the depreciation of energy in the system.

### REFERENCES

- Bencardino, F., Condello, A., and Ashour, A. F. (2017). "Single-lap shear bond tests on steel reinforced geopolymeric matrix-concrete joints". *Composites-Part B: Engineering*, 110, 62-71.
- Canbolat, B. A., Parra-Montesinos, G.J., and Wight, J. K. (2005). "Experimental study on seismic behaviour of high-performance fiber-reinforced cement composite coupling beams". *ACI Structural Journal*, 102 (1), 159.
- Cho, C. G., Kim, Y. Y., Feo, L., and Hui, D. (2012). "Cyclic responses of reinforced concrete composite columns strengthened in the plastic hinge region by HPFRCC mortar". *Composite Structures*, 94 (7), 2246-2253.
- Choi, W.C., Jang, S. J., and Yun, H.D. (2017). "Bond and cracking behaviour of lap-spliced reinforcing bars embedded in hybrid fiber-reinforced strain-hardening cementitious composite (SHCC)". *Composites-Part B: Engineering*, 108, 35-44.
- Conforti, A., Tiberti, G., and Plizzari, G. A. (2016). "Splitting and crushing failure in FRC elements subjected to a high concentrated load". *Composites-Part B: Engineering*, 105, 82-92.
- Dang, Z., Liang, X., and Deng, M. (2016). "Cyclic behaviour of shear walls with HPFRCCs in the inelastic deformation critical region". *Structural Design of Tall and Special Buildings*, 25 (17), 886-903.
- Fischer, G., and Li, V.C. (2002). "Effect of matrix ductility on the performance of reinforced ECC column members under reversed cyclic loading conditions".
- Foltz, R. R., Lee, D. H., and LaFave, J. M. (2017). "Biaxial behaviour of high-performance fiber-reinforced cementitious composite plates". *Construction and Building Materials*, 143, 501-514.
- Help of ABAQUS. (2008). "Getting started with ABAQUS".
- Jen, G., Trono, W., and Ostertag, C.P. (2016). "Self-consolidating hybrid fiber-reinforced concrete: development, properties and composite behaviour". *Construction and Building Materials*, 104, 63-71.
- JSCE. (2008). Recommendations for design and construction of high-performance fiber-reinforced cement composites (HPFRCCs) with multiple fine cracks.
- Kang, S. H., Hong, S. G., and Kwon, Y. H. (2017). "Effect of permanent formwork using ultra-high-performance concrete on structural behaviour of reinforced concrete beam subjected to bending as a function of reinforcement parameter". *Journal of Applied Mechanical Engineering*.
- Mahjoubi, S., and Maleki, S. (2016). "Seismic performance evaluation and design of steel structures equipped with dual-pipe dampers". *Journal of Constructional Steel Research*, 122, 25-39.

- Maleki, S., and Bagheri, S. (2010). "Pipe dampers, part I: experimental and analytical study". *Journal of Constructional Steel Research*, 66 (8-9), 1088-1095.
- Na, C., and Kwak, H. G. (2011). "A numerical tension-stiffening model for ultra-high-strength fiber-reinforced concrete beams". *Computers and Concrete*, 8 (1), 1-22.
- Ngekpe, B.E., Gualo, C., and Abbey, S. J. (2019). "Dynamic analysis of footbridge to Eurocode (case study on Leventis Footbridge, Aba Road, Port Harcourt)". *Jordan Journal of Civil Engineering*, 13(1), 149-157.
- Olsen, E. C., and Billington, S. L. (2011). "Cyclic response of precast high-performance fiber-reinforced concrete infill panels". *ACI Structural Journal*, 108 (1).
- Parra-Montesinos, G. J., and Chompreda, P. (2007). "Deformation capacity and shear strength of fiber-reinforced cement composite flexural members subjected to displacement reversals". *Journal of Structural Engineering*, 133 (3), 421-431.
- Pokhrel, M., and Bandelt, M. J. (2019). "Material properties and structural characteristics influencing deformation capacity and plasticity in reinforced ductile cement-based composite structural components". *Composite Structures*, 224, 111013.
- Quang, K.M., Dang, V.P., Han, S.W., Shin, M., and Lee, K. (2016). "Behaviour of high-performance fiber-reinforced cement composite columns subjected to horizontal biaxial and axial loads". *Construction and Building Materials*, 106, 89-101.
- Shbeeb, N.I., and Al-Rousan, R.Z. (2018). "Vibration analysis of thermoplastic railroad bridge". *Jordan Journal of Civil Engineering*, 12 (1), 70-77.
- Wang, S., and Li, V. C. (2005). "Polyvinyl alcohol fiber-reinforced engineered cementitious composites: material design and performance". In: *Proc., Int'l. Workshop on HPFRCC Structural Applications, Hawaii*.
- Wu, C., Pan, Z., Su, R. K. L., Leung, C. K. Y., and Meng, S. (2017). "Seismic behaviour of steel-reinforced ECC columns under constant axial loading and reversed cyclic lateral loading". *Materials and Structures*, 50 (1), 78.
- Wu, X., Kang, T. H. K., Lin, Y., and Hwang, H. J. (2018). "Shear strength of reinforced concrete beams with precast high-performance fiber-reinforced cementitious composite permanent form". *Composite Structures*, 200, 829-838.
- Yuan, F., Pan, J., Xu, Z., and Leung, C. K. Y. (2013). "A comparison of engineered cementitious composites *versus* normal concrete in beam-column joints under reversed cyclic loading". *Materials and Structures*, 46 (1-2), 145-159.